

# OPERATOR'S MANUAL

---

MODEL 4413  
16-CHANNEL CAMAC  
DISCRIMINATOR

October 1987

---

# LeCroy

**Innovators in Instrumentation**

**Corporate Headquarters**

700 Chestnut Ridge Road  
Chestnut Ridge, NY 10977-6499  
Tel: (914) 425-2000, TWX: 710-577-2832

**European Headquarters**

Route du Nant-d'Avril 101  
1217 Meyrin 1  
Geneva Switzerland  
Tel: (022) 82 33 55

Copyright® May 1987, LeCroy. All rights reserved. Information in this  
publication supersedes all earlier versions. Specifications subject to change

## CAUTION

---

### COOLING

The high power dissipation of the 4413 requires that it be well cooled. Be sure fans move sufficient air to maintain exhaust air temperature at less than 50°C.

### 6 V POWER REQUIREMENT

The 4413 uses significant power from -6 V power line. Be sure that your crate can supply enough current to this and other modules, especially if multiple 4413s are to be used.

### INSTALLATION

Crate power should be turned off during insertion or removal of modules to avoid possible damage caused by momentary misalignment of contacts.

### SPECIFICATIONS

The information contained in this manual is subject to change without notice. The reference for product specification is the Technical Data Sheet effective at the time of purchase.

# TABLE OF CONTENTS

<b>1 General Information</b>	
Purpose	1
Unpacking and Inspection	1
Warranty	1
Product Assistance	1
Maintenance Agreements	1
Documentation Discrepancies	2
Software Licensing Agreement	2
<b>2 Product Description</b>	
Overview	3
Specifications	4
Controls and Connectors	6
CAMAC Commands	11
<b>3 Installation</b>	
General	13
Cables	13
<b>4 Operating Instructions</b>	
Threshold	15
Output Width	17
Test Mode	17
Retiming Mode	18
<b>5 Theory Of Operation</b>	
General	21
Discriminator	21
Width Control	21
Threshold	21
Veto and Mask	23
Sync-Strobe	23
Test	23
Analog Sum	23
CAMAC Decoder	23
Power Distribution	24

**PURPOSE**

This manual is intended to provide instruction regarding the setup and operation of the covered instruments. In addition, it describes the theory of operation and presents other information regarding its functioning and application.

The Service Documentation, packaged separately, should be consulted for the schematics, parts lists and other materials that apply to the specific version of the instrument as identified by its ECO number.

**UNPACKING AND INSPECTION**

It is recommended that the shipment be thoroughly inspected immediately upon delivery. All material in the container should be checked against the enclosed Packing List and shortages reported promptly. If the shipment is damaged in any way, please notify the Customer Service Department or the local field service office. If the damage is due to mishandling during shipment, you may be requested to assist in contacting the carrier in filing a damage claim.

**WARRANTY**

LeCroy warrants its instrument products to operate within specifications under normal use and service for a period of one year from the date of shipment. Component products, replacement parts, and repairs are warranted for 90 days. This warranty extends only to the original purchaser. Software is thoroughly tested, but is supplied "as is" with no warranty of any kind covering detailed performance. Accessory products not manufactured by LeCroy are covered by the original equipment manufacturers warranty only.

In exercising this warranty, LeCroy will repair or, at its option, replace any product returned to the Customer Service Department or an authorized service facility within the warranty period, provided that the warrantor's examination discloses that the product is defective due to workmanship or materials and has not been caused by misuse, neglect, accident or abnormal conditions or operations.

The purchaser is responsible for the transportation and insurance charges arising from the return of products to the servicing facility. LeCroy will return all in-warranty products with transportation pre-paid.

This warranty is in lieu of all other warranties, express or implied, including but not limited to any implied warranty of merchantability, fitness, or adequacy for any particular purpose or use. LeCroy shall not be liable for any special, incidental, or consequential damages, whether in contract, or otherwise.

**PRODUCT ASSISTANCE**

Answers to questions concerning installation, calibration, and use of LeCroy equipment are available from the Customer Services Department, 700 Chestnut Ridge Road, Chestnut Ridge, New York 10977-6499, (914) 578-6059, or your local field service office.

**MAINTENANCE AGREEMENTS**

LeCroy offers a selection of customer support services. For example, Maintenance agreements provide extended warranty that allows the customer to budget maintenance costs after the initial warranty has expired. Other services such as installation, training, on-site repair, and addition of engineering improvements are available through spe-

cific Supplemental Support Agreements. Please contact the Customer Service Department or the local field service office for details.

## **DOCUMENTATION DISCREPANCIES**

LeCroy is committed to providing state-of-the-art instrumentation and is continually refining and improving the performance of its products. While physical modifications can be implemented quite rapidly, the corrected documentation frequently requires more time to produce. Consequently, this manual may not agree in every detail with the accompanying product and the schematics in the Service Documentation. There may be small discrepancies in the values of components for the purposes of pulse shape, timing, offset, etc., and, occasionally, minor logic changes. Where any such inconsistencies exist, please be assured that the unit is correct and incorporates the most up-to-date circuitry.

## **SOFTWARE LICENSING AGREEMENT**

Software products are licensed for a single machine. Under this license you may:

- Copy the software for backup or modification purposes in support of your use of the software on a single machine.
- Modify the software and/or merge it into another program for your use on a single machine.
- Transfer the software and the license to another party if the other party accepts the terms of this agreement and you relinquish all copies, whether in printed or machine readable form, including all modified or merged versions.

## OVERVIEW

The LeCroy Model 4413 is a 16-input discriminator in a single-width CAMAC module. Three modes of operation are provided; Updating, Burst Guard and Retiming Mode. The module accepts NIM level inputs and operates to 150 MHz. The outputs of the 4413 are differential ECL levels which are compatible with LeCroy's ECLine series of programmable logic modules. Output widths are adjusted from 3.5 nsec to 100 nsec in the Update mode. Figure 1 shows the front-panel layout.

Each of the 16 channels share a common threshold which is set by a front-panel potentiometer or via CAMAC commands. The threshold range extends from -15 mV to -1 V. The unit also has a common front-panel VETO input as well as a TEST input. However, the TEST mode can also be initiated by CAMAC commands and only desired channels may be tested using a CAMAC write mask command. In addition, the unit has two bridge outputs which generate a current proportional to the input multiplicity.

The high density is made possible through the use of eight HVL201 hybrids. These hybrids enhance the reliability of the Model 4413 as well as provide for the 150 MHz counting rate operation.

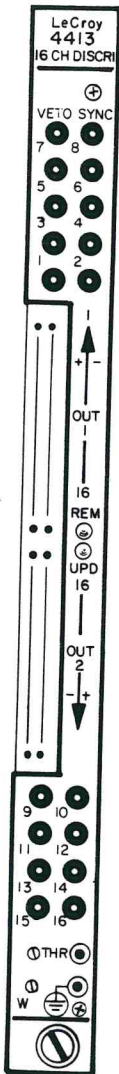

Figure 1  
Front Panel Layout

### SPECIFICATIONS

#### Input Characteristics

**Signal Inputs:** sixteen inputs via Lemo front-panel connectors,  $50\ \Omega \pm 2\%$ , protected to  $\pm 5\ \text{A}$  for  $0.5\ \mu\text{sec}$ , clamping at  $\pm 5\ \text{V}$ . Reflections  $< 4\%$  for input pulses of  $2\ \text{nsec}$  risetime. Stability better than  $0.25\%/^{\circ}\text{C}$  to  $60^{\circ}\text{C}$  operating range. Offset  $\pm 3\ \text{mV}$ .

**Threshold:**  $-15\ \text{mV}$  to  $-1\ \text{V} \pm 5\%$  or  $5\ \text{mV}$ , whichever is greater; front-panel screwdriver adjust in local or threshold 10-bit DAC in remote mode.

**Threshold Monitor:** front-panel test point has 10:1 ratio of monitor voltage to actual voltage  $\pm 5\%$ .

**Hysteresis:** typical  $3.5\ \text{mV}$ .

**Test Input:** one input via a Lemo connector on the front panel,  $50\ \Omega \pm 2\%$ . Requires NIM level direct coupled signal ( $< -600\ \text{mV}$ ) to trigger all channels. Minimum width:  $3\ \text{nsec}$ . Maximum rate:  $150\ \text{MHz}$ .

**Veto Input:** one input via a Lemo front-panel connector,  $50\ \Omega \pm 2\%$ , permits simultaneous fast inhibiting of all channels; requires NIM level signal ( $< -600\ \text{mV}$ ). Direct coupled. Must precede input signal by approximately  $1\ \text{nsec}$  and overlap its leading edge in Updating mode or overlap complete input signal in Burst Guard mode. Minimum duration:  $3\ \text{nsec}$ .

**Sync-Strobe Input:** One Lemo front-panel connector,  $50\ \Omega \pm 2\%$ . Requires complementary NIM level signals. When using this input the Sync-Strobe pulse leading edge will determine the output timing, while the output width will be determined by the overlap of the unstrobed outputs and the Sync-Strobe pulse. Inputs to be retimed must precede Sync-Strobe pulse by  $10\ \text{nsec}$  minimum. Also, ensure that the width of the unstrobed discriminator output completely overlaps this pulse.

#### Output Characteristics

**Discriminator Outputs:** Two separate outputs per channel. ECL level ( $-0.8, -1.7\ \text{V}$ ) into  $100\ \Omega$  twisted pair. Duration, approximately  $3.5\ \text{nsec}$  to  $100\ \text{nsec}$ , continuously variable via screwdriver control, common to all channels. Risetimes and falltimes  $< 2\ \text{nsec}$ . Width stability better than  $0.3\%/^{\circ}\text{C}$  maximum.

**Current Sum Outputs:** Two bridged, rear-panel, Lemo connectors; high impedance current source; generates a current proportional to the input multiplicity at the rate of  $-2\ \text{mA} \pm 10\%$  per hit;  $100\ \text{MHz}$  maximum rate. The two connectors can be used for daisy chaining within a group of similar units.

**Output Operation Modes:** Updating or Burst Guard operation selectable by rear-panel switch. Retiming mode active when using the Sync-Strobe input.

#### Timing Characteristics

**Double Pulse Resolution:**  $5\ \text{nsec}$  typical.

The speed of a discriminator is practically defined by its double pulse resolution or the time between the leading edges of the most closely spaced pulse pairs for which the discriminator produces two distinct output pulses. Although simple in concept, this specification can be



misleading unless the input conditions are precisely defined and ambiguities in performance are disclosed. One should indeed investigate the double pulse resolution as a function of the input amplitude over threshold and of the input width.

**Tracking Error:** Tests on the 4413 show a tracking error typically not in excess of 200 psec.

The ability of a discriminator to be used for precise timing (coincidence or TOF) in an environment which encounters narrow pulse pair separations is demonstrated by considering the time shift (or tracking error) introduced as the time interval between successive inputs is reduced. In an experiment, tracking error is equivalent to time dispersion as a function of input rate. For many experiments, this can be critical, since it is often in high rate situations that the best timing resolution is required.

**Time Slewing:** <500 psec for input amplitudes from 2 times to 20 times over threshold. See Figure 2.

Slewing is the variation in propagation delay from the beginning of the pulse input to the output pulse as a function of input pulse amplitude. The intrinsic slewing is measured as a function of input crossing threshold to output pulse. In addition, pulses of varying risetimes give different delays from the beginning of the pulse since the threshold crossing time relative to the pulse's leading edge depends upon the amplitude of the pulse. Only the intrinsic slewing is specified for the Model 4413 since risetime slewing is application dependent.

Slewing is typically measured as the difference between propagation delay for input pulse amplitudes twice that of threshold and input pulses whose amplitudes are 20 times threshold. Threshold is defined as the input pulse level which results in discriminator firing for 50% of the pulses.

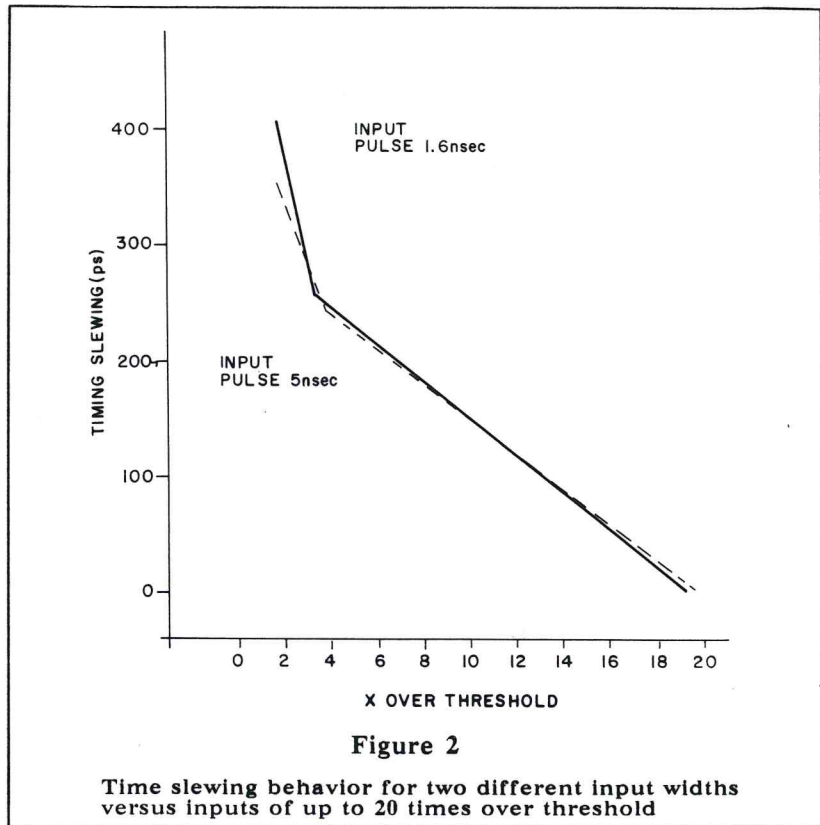

**General**

**Maximum Rate:** 150 MHz.

**Input-Output Delay:** <18 nsec.

**Test-Output Delay:** <18 nsec.

**Multiple Pulsing:** None: one and only one output pulse is produced for each input pulse regardless of input pulse amplitude and duration.

**Sync-Strobe to Output Delay:** 9 nsec  $\pm$ 0.5 nsec

**LED Indicators:** Two front-panel LED's respectively indicate, when lit, that programmable mode and Updating operation have been selected.

**Burst Guard™:** A rear-panel switch enables the Burst Guard or Updating operation for all channels.

**Power Requirements:** +24 V at 0.03 A; +6 V at 1.3 A;  
-6 V at 4.1 A; -24 V at 0.03 A.

**CONTROL AND CONNECTORS**

**Signal Input**

Signal input to each of the 16 channels is made via a front-panel Lemo connector. The inputs of 4413 discriminator are protected to 5 A for 0.5  $\mu$ sec, clamping at  $\pm$ 5 V.

The DC protection is limited by the 0.25 W dissipation limit of the input resistor, which can be assumed to offer protection against DC signals less than 5 V.

Input reflections for the 4413 are less than 4% with 2 nsec input pulses.

#### Threshold

The threshold range of the 4413 Octal Discriminator is from  $-15$  mV to  $-1$  V and is adjustable by a front-panel, 15 turn potentiometer. Threshold is increased by turning this control clockwise. Alternatively, threshold can be programmed by CAMAC F(17) command. In either case, threshold is common to all channels and the adjustment is uniform and does not present any discontinuity or changes in sensitivity.

A front-panel test point is a 10:1 monitor of the actual threshold value within  $\pm 5\%$ . The output impedance of the test point is  $1$  k $\Omega$ , so a high impedance digital voltmeter should be used.

#### Test Input

A rear-panel Test input allows all channels to be triggered once a negative NIM pulse is received. This useful feature allows complete testing of the module without removing any input cable and also permits the use of the 4413 as a 32-fold fan-out. The Test pulse will have the same effect as a similar pulse on the normal inputs. In particular, the output width in Burst Guard mode will be proportional to the input width.

#### VETO Input

A common front-panel Lemo input connector allows vetoing of all channels simultaneously, when a negative NIM pulse is applied. A complementary NIM signal applied to the VETO input permits the 4413 to be used as an 16-channel strobed coincidence unit. In other words, the discriminators will only generate an output when the input level exceeds the set threshold and while these signals occur during a logical 0 ( $\geq -100$  mV) state of the complementary input to the VETO.

However, the action of the VETO input can be different depending on the operation mode of the unit (Updating or Burst Guard) and on the static level of the VETO input (see Figure 3).

**Updating mode:** In the Updating mode, the leading edge of the input pulse triggers the discriminator timing stage. A VETO input must be coincident and precede the input pulse leading edge by 1 nsec for the input to be inhibited.

**Burst Guard mode (time over threshold):** When the Burst Guard section is enabled an overlap coincidence between the discriminator output and the VETO pulse is activated. A negative VETO pulse of the same width as the discriminator output will VETO the output during this time. If a pulse wider than the VETO pulse is applied at the input, an output will result due to the part of the pulse exceeding the VETO. Therefore an efficient VETO should completely overlap the input pulses.

The same applies when a complementary NIM VETO pulse is used to gate or enable the module. The gate pulse should completely overlap the input pulses. In this case the unit is working as a strobed overlap coincidence unit.

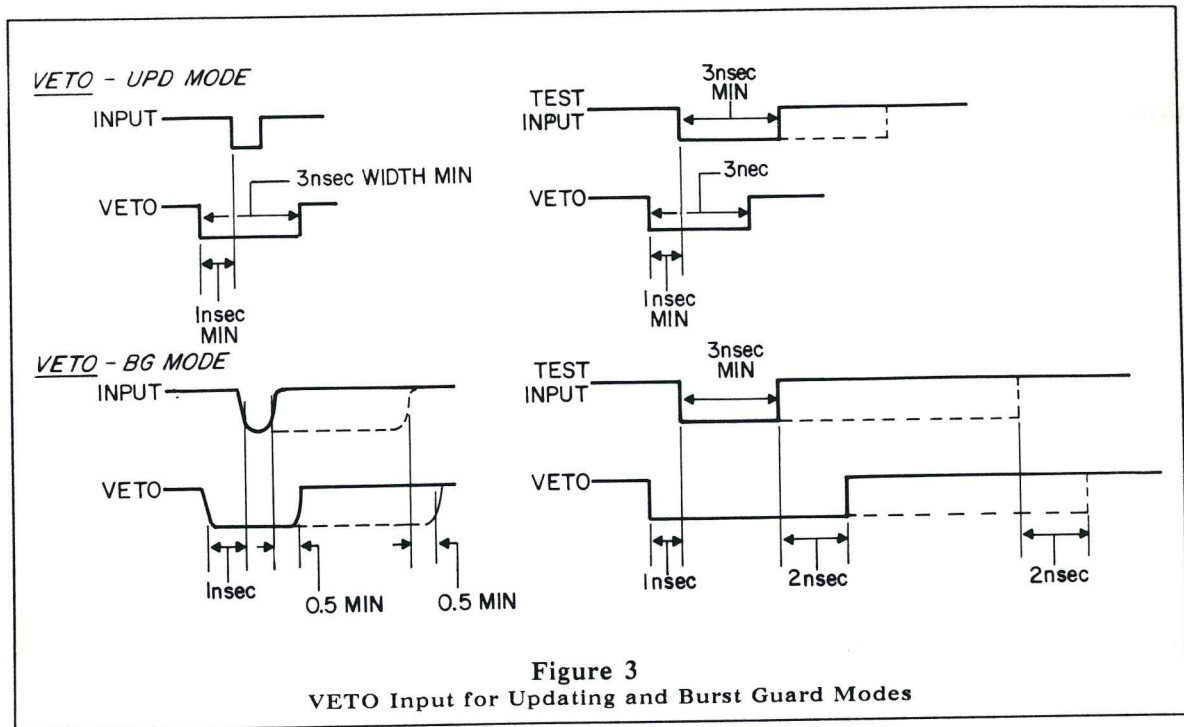

Figure 3  
VETO Input for Updating and Burst Guard Modes

Sync-Strobe Input

A front-panel LEMO connector allows retiming of the output pulses which are not coincident in time, within a window defined by VETO and a common synchronization pulse. The Sync-Strobe input allows realignment of all output leading edges with the leading edge of the synchronization pulse to within  $\pm 0.5$  nsec. The Sync-Strobe Input requires complementary NIM signal levels.

Inputs to the 4413 which exceed threshold and which are to be retimed must precede the Sync-Strobe pulse by 10 nsec minimum and should completely overlap this pulse to avoid variable width outputs. For more details see Chapter 4, Operating Instructions.

Output

The output of 4413 is differential ECL pulse pairs suitable for driving twisted-pair cables. Two outputs per channel are provided from two 34-pin front-panel connectors.

The output of selected channels in the TEST mode can be disabled or masked by loading a 16-bit word via CAMAC F(16) command into a storage register.

Width Adjustment

The output width is common for each channel and is continuously adjustable via front-panel potentiometer from 3.5 nsec to  $>100$  nsec in the Updating mode. Minimum width is set by turning the potentiometer fully counter clockwise.

The main contributors to output width uncertainty are a function of the external conditions. Variations in both temperature and supply voltage can cause significant changes in output width.

Width temperature coefficient has been measured to be  $<0.3\%/^{\circ}\text{C}$  while the voltage coefficient is negligible because of the onboard stabilization of the current at  $-5.0$  V.

## Current Sum Output

An analog signal which is proportional to the number of channels which exceed the threshold is available via bridged rear-panel Lemo connectors. This analog majority information consists of  $2 \text{ mA} \pm 10\%$  per enabled channel for the duration of that channel (minimum of 10 nsec). When using only one connector with a  $50 \Omega$  load, the voltage step is  $100 \text{ mV/hit}$ . When both outputs are used with  $50 \Omega$  loads, the output is  $50 \text{ mV/hit}$ . The output amplitude is limited to a maximum of  $1.6 \text{ V}$ . The two connectors allow cascading of several units if needed. In this case, care should be taken to terminate the unused output to avoid reflectors. Figure 4 shows an example of the current sum output with only one load.

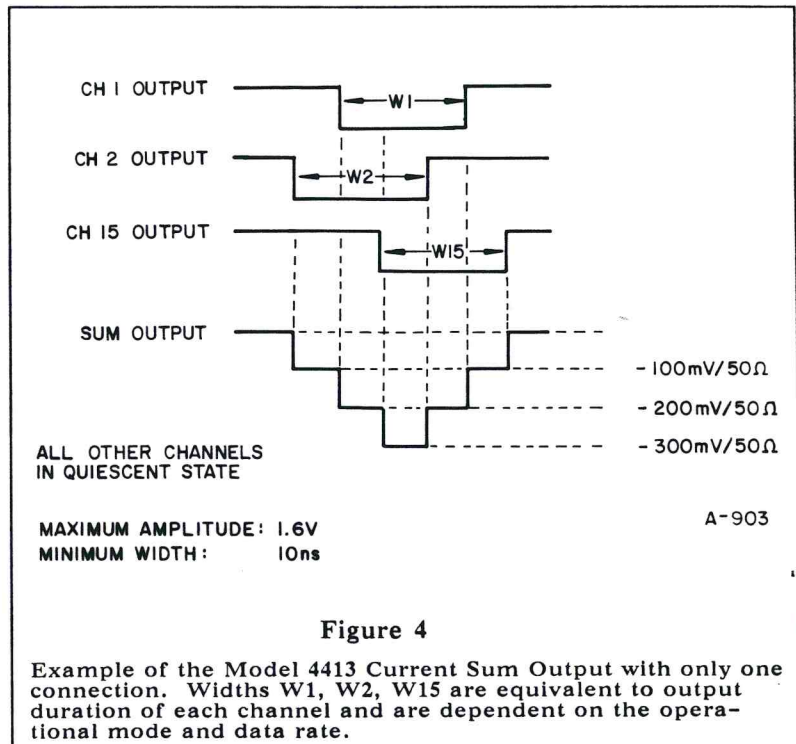

Figure 4

Example of the Model 4413 Current Sum Output with only one connection. Widths  $W_1$ ,  $W_2$ ,  $W_{15}$  are equivalent to output duration of each channel and are dependent on the operational mode and data rate.

Updating/Burst  
Guard Switch

The module has a rear-panel switch which allows the selection of the operational mode. See Figure 5 for a comparison.

**Updating:** In Updating mode, the output is extended if a second pulse arrives before the first output returns to zero, as long as the second pulse arrives at a time later than the double pulse resolution of the unit. Thus, the second pulse will be seen by the front end of the unit even though an output pulse is still present from the first signal. The second pulse will cause a new output to be generated and added (in time) to the portion of the original output already occurring.

**Burst Guard:** In Burst Guard mode, the output of the front end is OR'd with the conventional mode output. For input pulses arriving at a rate which exceeds the double pulse resolution of the unit, the discriminator output duration will be equal to the time interval between the first leading edge threshold crossing and the last trailing edge threshold recrossing or the preset output width, whichever is greater.

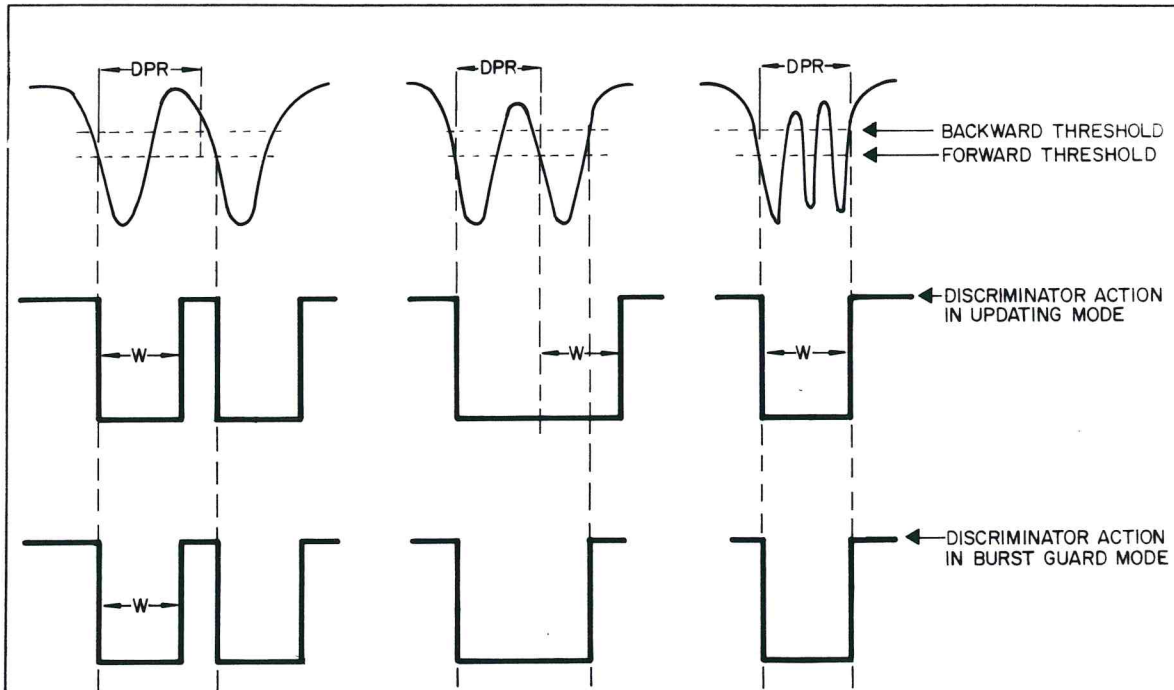

A-880

Figure 5

Comparison of Updating and Burst Guard mode with various fast input signals. DPR is the double pulse resolution interval and W is the selected output width which is set to a minimum in this example.

This feature is especially important in veto applications when the discriminator output must be enabled as the detector is hit by unwanted and unmeasurable high rates. A discriminator without Burst Guard would see the first pulse and generate the preset output width, but would be paralyzed at quiescent level or would trigger only randomly for subsequent pulses separated by less time than the DPR of the unit. Burst Guard assures a logical 1 output level during these high rate bursts.

Burst Guard mode is also useful in any application where the output width has to be proportional to the input width.

**CAMAC Commands**

The commands for the 4413 conform to the CAMAC Standard-IEEE Std 583-1975. If the user is unfamiliar with the CAMAC standard, a good reference is *CAMAC Instrumentation and Interface Standards*. It is published by: The Institute of Electrical and Electronics Engineers, Inc., 345 East 47th Street, New York, NY 10017.

Further information is available from LeCroy Corporation in the form of Application Notes. In particular, AN-33, *Introduction to CAMAC*, is very useful.

Please note that at power-on the module defaults to the Local mode of operation and the mask register is cleared. The module can be set to the Remote mode by a F(26)•A(0) CAMAC command. Consult Table 1 for the CAMAC functions which are executed in the Local mode.

Z: Clears mask register at S2 time, sets module into Local mode.

N•F(0)•A(0): Reads mask register. Q response in Remote mode only.

N•F(1)•A(0): Reads threshold setting when in Local or Remote mode.

N•F(16)•A(0): Writes mask register pattern (W1-W16). Executable and Q response generated in Remote mode only.

N•F(17)•A(0): Writes threshold setting register; 11 bits, 10 bits of data (W1-W10) providing 1 mV resolution are used to program common threshold and 1 bit (W11) to set the manual threshold value (front-panel screwdriver control) to the threshold register.

In this case, the data presented on W1-W10 is ignored. Executable and Q response generated in Remote mode only.

N•F(25)•A(0): Test function. Only channels not masked off by F(16) are triggered by internally generated 3 nsec wide pulse. Executable and Q response generated in Remote mode only.

N•F(24)•A(0): Set Local mode.

N•F(26)•A(0): Set Remote mode.

#### CAMAC Responses

X: An X=1 response is generated for every valid F,N,A.

Q: A Q=1 response is generated if the valid command can be executed.

**Table 1**  
**List of Executable CAMAC Functions in the Local Mode of Operation.**

F(0) • A(0)	read mask	is executed	no Q-response
F(1) • A(0)	read threshold	is executed	Q-response
F(16) • A(0)	write mask	is not executed	no Q-response
F(17) • A(0)	write threshold	is not executed	no Q-response
F(24) • A(0)	set on Local mode	is not executed	no Q-response
F(25) • A(0)	generates Test	is not executed	no Q-response
F(26) • A(0)	set on Remote mode	is executed	Q-response
Z	sets on Local mode and clears mask		

Note that threshold is manually adjustable in this mode.

## GENERAL

The Model 4413 is a CAMAC module and as such must be installed in a CAMAC crate. Care must be taken to ensure the crate power is off before the module is installed. It can be installed in any slot except the crate controller slot (slots 24 and 25).

The 4413 requires significant power from the crate due to its high working frequency. It should be determined prior to installation whether the crate can support one or more 4413's with other modules which are to be used in the crate.

Once the unit is in the crate, input signals must be applied to the front-panel connectors. Then the minimum output width must be adjusted via the front-panel potentiometer and the threshold set either by the front-panel control or via CAMAC commands. The threshold can be monitored via a front-panel test point with a voltmeter. The output of this connector is a 10 to 1 ratio with the actual applied threshold voltage level.

To complete cable connections to the 4413, the VETO, Sync-Strobe and Test signals, if utilized, must be connected. Of course, outputs of the unit must be connected to associated units including the current sum output if desired.

## CABLES

Interconnections between the output of the Model 4413 and various other ECLine modules can be made either by multiwire cables or by single twisted-pair cables for one-to-one connections suitable for the transmission of differential ECL pulse pairs. Such interconnecting cables can be purchased from LeCroy. In particular there are two types of 34 conductor multiwire cables available, one for short connections using flat cable and the second for long connections using twisted and flat ribbon cable.

The model numbers of such cables are as follows:

STC-DC/34-L - flat multiwire cable for short interconnections

LTC-DC/34-L or DC2/34-L - twisted-pair multiwire cable for long interconnections

STP-DC/02-L - single twisted-pair cable, 3 ft maximum length

*NOTE that L is the cable length in feet that must be specified by the user.*

Inputs to the 4413 are lemo connections so that standard Lemo-to-Lemo cables can be used such as the LeCroy:

480-122-301 3 ft RG 174 cable  
 480-101-003 1 ft RG 174 cable  
 480-216-002 6 ft RG 58/L cable.



## GENERAL

Setup of the Model 4413 can be split into four categories: adjustment of the threshold and output width, initiating the Test mode and using the Retiming mode of operation.

## Threshold

The main function of the discriminator is to generate a logic pulse output when the input exceeds a given threshold. Therefore, correct adjustment of the threshold is one of the most important duties to be performed.

The threshold is adjusted via a front-panel potentiometer or programmed via CAMAC. The resulting change in threshold level is monitored with a high impedance voltmeter connected to the front-panel connector. The threshold can be set at some level which corresponds to a physical quantity (i.e., 100 mV may equal 100 keV) or it can be set above the noise level depending on the application. In either case, it is necessary to determine the level that the threshold should be set to. This action may be as easy as measuring the maximum noise level input or as complex as calibrating the system by accurately determining the relationship between pulse height (voltage level) and some quantity.

There are several phenomena to be aware of when setting the threshold since the actual value can be a function of environmental conditions as well as internal properties of the module itself.

Threshold  
Uncertainty

The external factors with the strongest effect upon the threshold value are the temperature coefficient of threshold and the power supply coefficient of threshold. Combining these, the actual threshold value  $V_T$  is given by:

$V_T$ : Threshold according to front-panel control setting  $\pm$  DC offset  $\pm$  temperature coefficient  $\times$  temperature change from calibration temperature  $\pm$  supply coefficient  $\times$  voltage change from nominal supply voltage.

For the 4413 the measured offset value is 0.6 mV and the temperature coefficient is 0.1 mV/°C. The power supply coefficient is negligible because the -5.0 V lines are stabilized on board.

Threshold  
Hysteresis

The 4413 discriminator has 3.5 mV hysteresis built into the front end. Every threshold crossing will not trigger the discriminator unless the previous signal has returned to below, for example, approximately -26.5 mV for threshold setting of -30 mV. This feature avoids multiple pulsing due to fine structure riding on a flat-topped pulse that may bring the pulse above and below threshold. Two examples below in Figure 6 illustrate this point.

In Example A of Figure 6 the input pulse will not retrigger the discriminator, if set for -30 mV threshold, even though it crosses the threshold level at a time exceeding the Double Pulse Resolution (DPR) of the unit.

In example B, the input signal does go back through the threshold of -30 mV but goes beyond to exceed the threshold plus hysteresis level. Two discriminator output pulses would result.

Since LeCroy discriminators are most often used with photomultipliers and plastic scintillators, and since the characteristic pulses out of this type of detector are typically smooth for each individual event, multiple outputs should occur only when they represent multiple events.

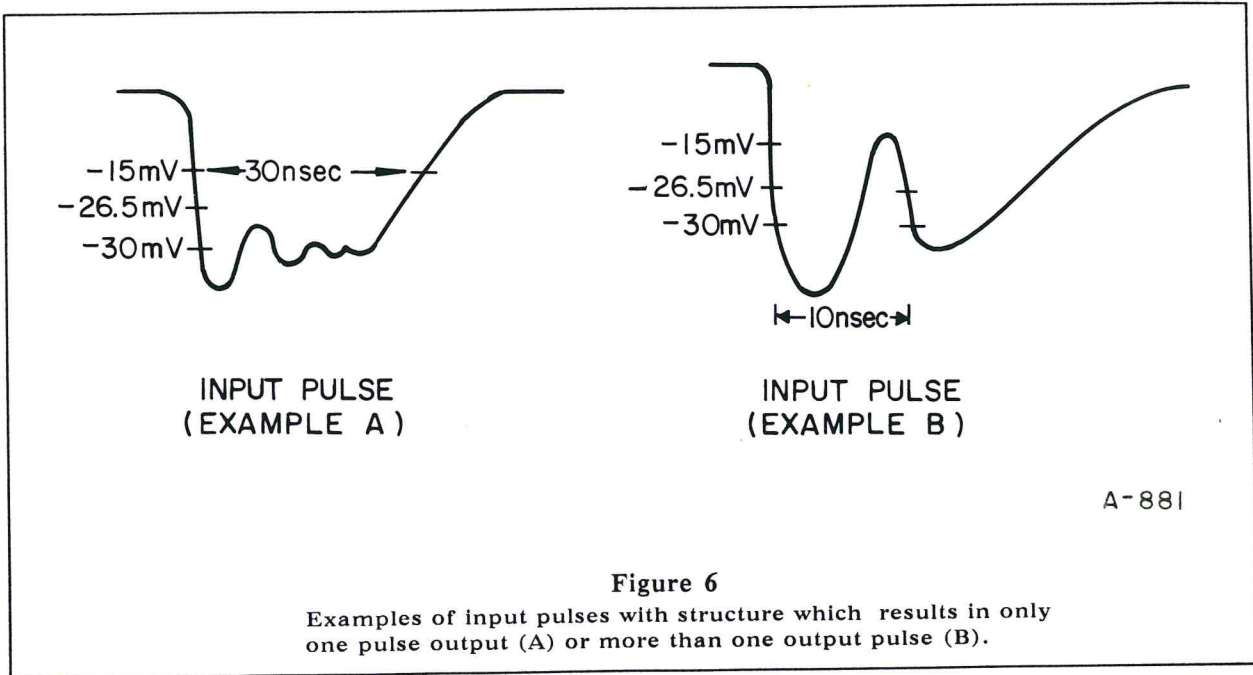

**Figure 6**  
Examples of input pulses with structure which results in only one pulse output (A) or more than one output pulse (B).

**MINIMUM INPUT CHARGE**

The 4413 requires a minimum input charge above the threshold to trigger. As a result, the discriminator threshold is input-pulse-width dependent, which is more apparent with shorter input widths.

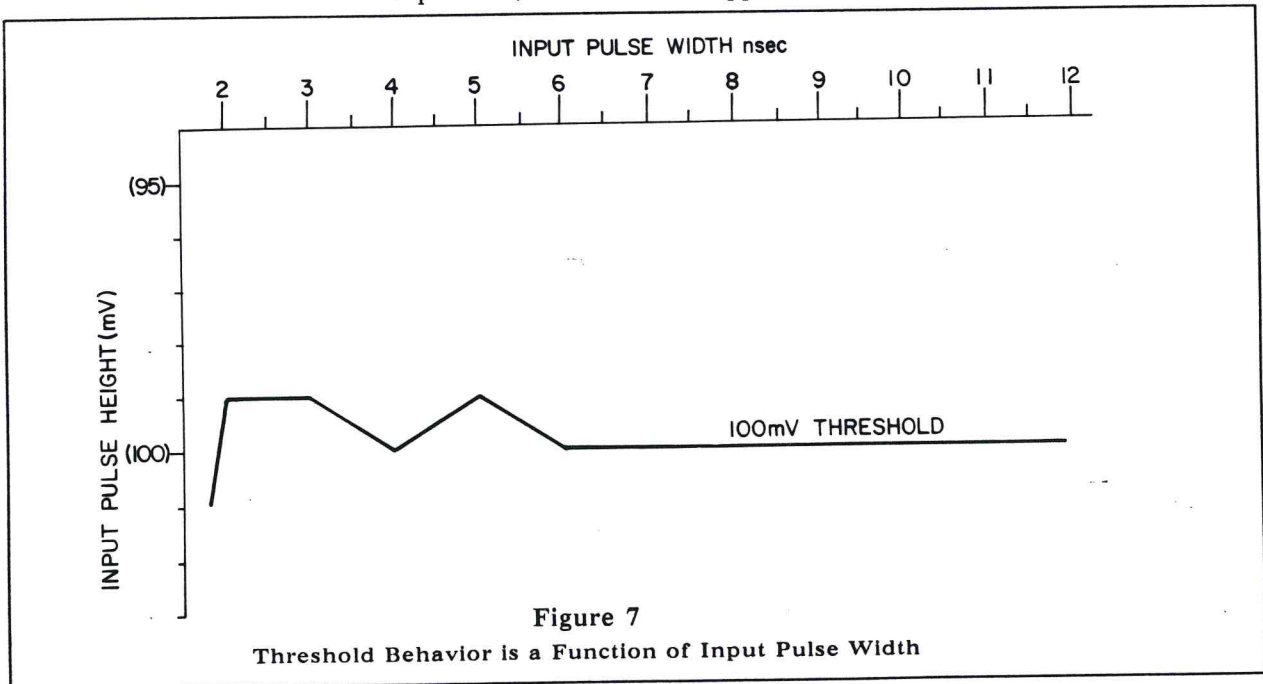

**Figure 7**  
Threshold Behavior is a Function of Input Pulse Width

Figure 7 shows a typical threshold behavior as a function of the input pulse width at 100 mV nominal threshold. The input pulse widths given have been measured at the half maximum.

**OUTPUT WIDTH**

The output of a discriminator is a logic pulse which can be used for various functions and purposes in the rest of the system. The output pulse width must be compatible with the equipment following the discriminator. However, the maximum repetition rate of the unit is limited by this width. Therefore, certain trade-offs may have to be made in determining the required output width.

The output width in the standard Updating mode is adjustable via a front-panel potentiometer. The width adjustment can be monitored by using a scope connected to one of the module's output connectors. Width is increased as the control is turned clockwise.

The output width in the Burst Guard mode will either be equivalent to the time over threshold of the input pulse or the preset width, whichever is greater.

**TEST MODE**

The 4413 permits rapid testing of output width for all discriminator channels as well as for the module in general by simulating inputs which exceed threshold. The Test function is also useful for checking other units in the system following the discriminator.

The Test mode may be initiated either locally or via CAMAC. The modules' default condition upon power-on is the Local mode where a >3 nsec wide NIM level signal on the rear panel connector is required to fire the discriminator. In this case, all channels output a logic level for the duration of the Test input in the Burst Guard mode or the preset width in the Updating mode.

To initiate Test via CAMAC, an F(26) command is sent to set the unit in the Remote mode. Then an output mask can be loaded via CAMAC F(16) with a 16-bit word if desired. Bits 1 to 16 in the data word correspond to discriminator channels 1 to 16 respectively. A "1" in any bit disables the corresponding channel of the discriminator, in Test mode, while a "0" enables the associated channel.

*Note that output masks are stored in a register in the 4413 and recalled whenever the Test mode is entered. Therefore, entering the mask word is needed only on initialization or when a change is required.*

A CAMAC F(25) command with any odd data word (i.e., W1=1) will trigger the test function. Channels which are not masked are subjected to an internally generated 3 nsec pulse.

The following is an example of a program written in FORTRAN to initialize and execute a Test. In this example the 4413 is presumed to be loaded in slot 10 of crate 1 on a parallel branch highway 1. It is also presumed that the user has CAMAC sub-routines similar to those described by ANSI/IEEE Std. 758-1979 IEEE Standard Subroutines for CAMAC.

- Perform Standard CAMAC Initialization Prior to TEST -

```

C
C Define unit
C
C     KRATE=1
C     ISLOT=10
C     NBRANCH=1
C     NADR=0
C
C Declare a CAMAC Register
C
C CALL CDREG (IDISC, NBRCH, KRATE, ISLOT, NADR)
C
C Load Mask to Disable Channel 0-7. Decimal Equivalent of 16-bit
C word is 255
C
C CALL CSSA (16, IDISC, 255, IQ)
C   If (.NOT.IQ) ERROR MESSAGE
C
C Now Fire Enabled Outputs Using CAMAC F(25) for 100 Times with
C 1 millisecond interval between tests
C
C DO 100 I=1,100
C   CALL CSSA (25, 1 DISC, 1 DUM, IQ)
C   CALL WAIT (1)
100 CONTINUE

```

### RETIMING MODE

The 4413 permits retiming of output pulse leading edges to within  $\pm 0.5$  nsec by use of the Retiming mode of operation. This mode requires a Sync-Strobe input which determines the timing of the outputs. In addition, a VETO pulse is usually used to determine a window in time which the outputs of the discriminators would be realigned. This mode of operation can be used in several different manners, depending on the application. One example is to eliminate different input delays to simultaneous pulses due to various lengths of cables between the detector and the 4413. The Retiming mode could solve this type of problem in the beginning of a system without the use of delay line modules later on. Of course, the Retiming mode should be used only with pulses in which the time of occurrence is not critical or for pulses which are known to be simultaneous.

Another example of the Retiming mode is shown in the following timing diagram. Since the threshold is common to all channels in this module and the point in time which a pulse exceeds threshold is dependent on risetime and amplitude, channels with longer risetimes will have outputs which occur later than those with faster risetimes. Additionally, channels with higher amplitudes will have outputs which precede those which are of lower amplitude. Therefore, use of the Retimed mode with pulses which occur at the same time but have different threshold crossing times due to the nature of the pulse shape allows adjustment or correction of the timing.

Use of the Retiming mode is shown pictorially in Figure 8. Pulses to be Retimed should occur within the time window defined by the VETO input. Note that if VETO is not used, output of the 4413 will be retimed only during the Sync-Strobe input pulse. All pulses to be retimed should precede the Sync-Strobe pulse by a minimum of 10 nsec due to the different internal delays with the module. Remember that the Sync-Strobe requires complementary signal levels. To ensure that the modules' outputs in the Retiming mode are of standard width, all of the unstrobed discriminator outputs should completely overlap

the Sync-Strobe pulse. Thus, either the discriminator output widths or the width of the Sync-Strobe pulse or both must be adjusted so this overlap occurs. The discriminator output width may be adjusted via the front-panel potentiometer if the BG/UPD switch is in the Updating position. In the Burst Guard position, the output width is dependent on the time over threshold or preset width, whichever is longer. Retiming output pulses will occur  $\pm 0.5$  nsec after the leading edge of the Sync-Strobe pulse and after the internal delay duration.

If the inputs do not precede the Sync-Strobe by more than 10 nsec, the output of the module in the Retiming mode will be the overlap of the Sync-Strobe action (Sync-Strobe pulse after 9 nsec propagation delay) and the discriminator actions (unstrobed discriminator outputs).

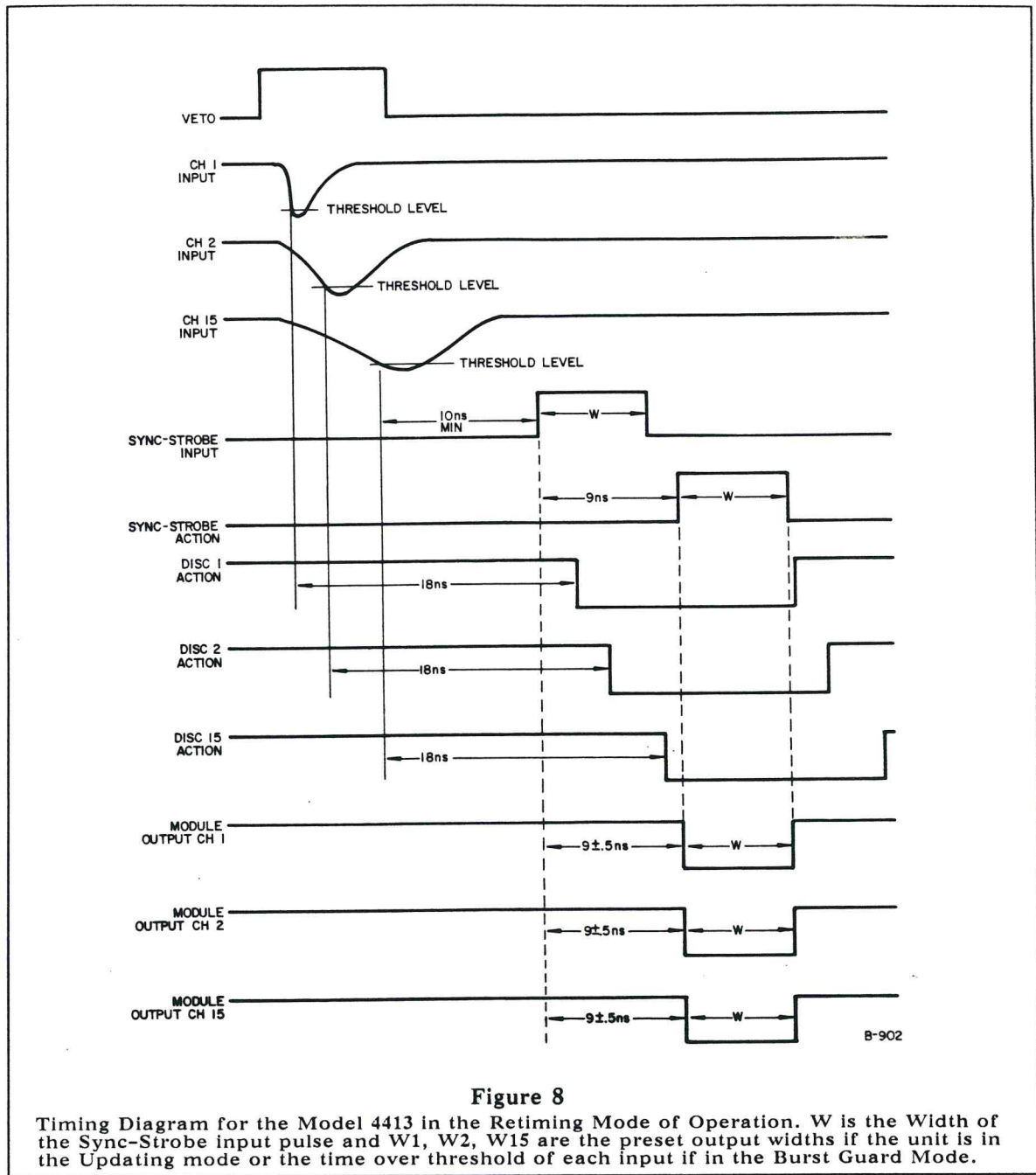

**Figure 8**

Timing Diagram for the Model 4413 in the Retiming Mode of Operation. W is the Width of the Sync-Strobe input pulse and W<sub>1</sub>, W<sub>2</sub>, W<sub>15</sub> are the preset output widths if the unit is in the Updating mode or the time over threshold of each input if in the Burst Guard Mode.

## GENERAL

The block diagram of the Model 4413 is shown in Figure 9. Nine different blocks can be individuated and will be discussed in the following sections:

*Discriminator hybrid*  
*Width adjustment circuitry*  
*Threshold adjustment circuitry*  
*Veto and mask circuitry*  
*Synchronization stage*  
*Test circuitry*  
*Analog sum circuitry*  
*CAMAC decoder*  
*Power distribution circuitry*

## Discriminator

Most of the discriminator circuitry, for two channels, is contained in a single LeCroy hybrid. The HVL210 was specifically developed for this module and was based on the LeCroy MVL407 monolithic comparator. The hybrid contains schematically the comparator, the vetoing circuitry as well as the circuitry for two operational modes (UPD and BG), a one shot and finally a current generator for the analog sum.

## Width Control

Width control is common to the 16 channels and it is performed by adjusting a front-panel 2 k $\Omega$  potentiometer referenced between ground and -5.0 V, via a voltage follower (E6, LM310 in sheet 2 of schematics).

A 100  $\Omega$  potentiometer (P19) is adjusted in order to set the maximum output width at 100 nsec. A 10 k $\Omega$  potentiometer per channel has been implemented to provide a means of equally calibrating all the channels in a module.

## Threshold

The threshold value, common to the 16 channels, is provided by a 10-bit Digital-to-Analog Converter (C4, DAC210 in sheet 4 of schematics). For a DAC setting between 0 and 15 counts, the threshold will be set to the minimum value of -15 mV. The maximum DAC setting of 1000 counts corresponds to a threshold of -1 V.

The digital input to the DAC is given by a 10-bit counter (M3, G3, H4, all of the 74LS191, sheet 6 of schematics) which can be parallel loaded through write lines W1-W10, under the control of F(17)•A(0)•S1, or serially loaded by an oscillator (G2, LS123 in sheet 4 of schematics). The comparator continuously samples the voltage value across the 2 k $\Omega$  front-panel potentiometer (P3) and compares it with the actual threshold value.

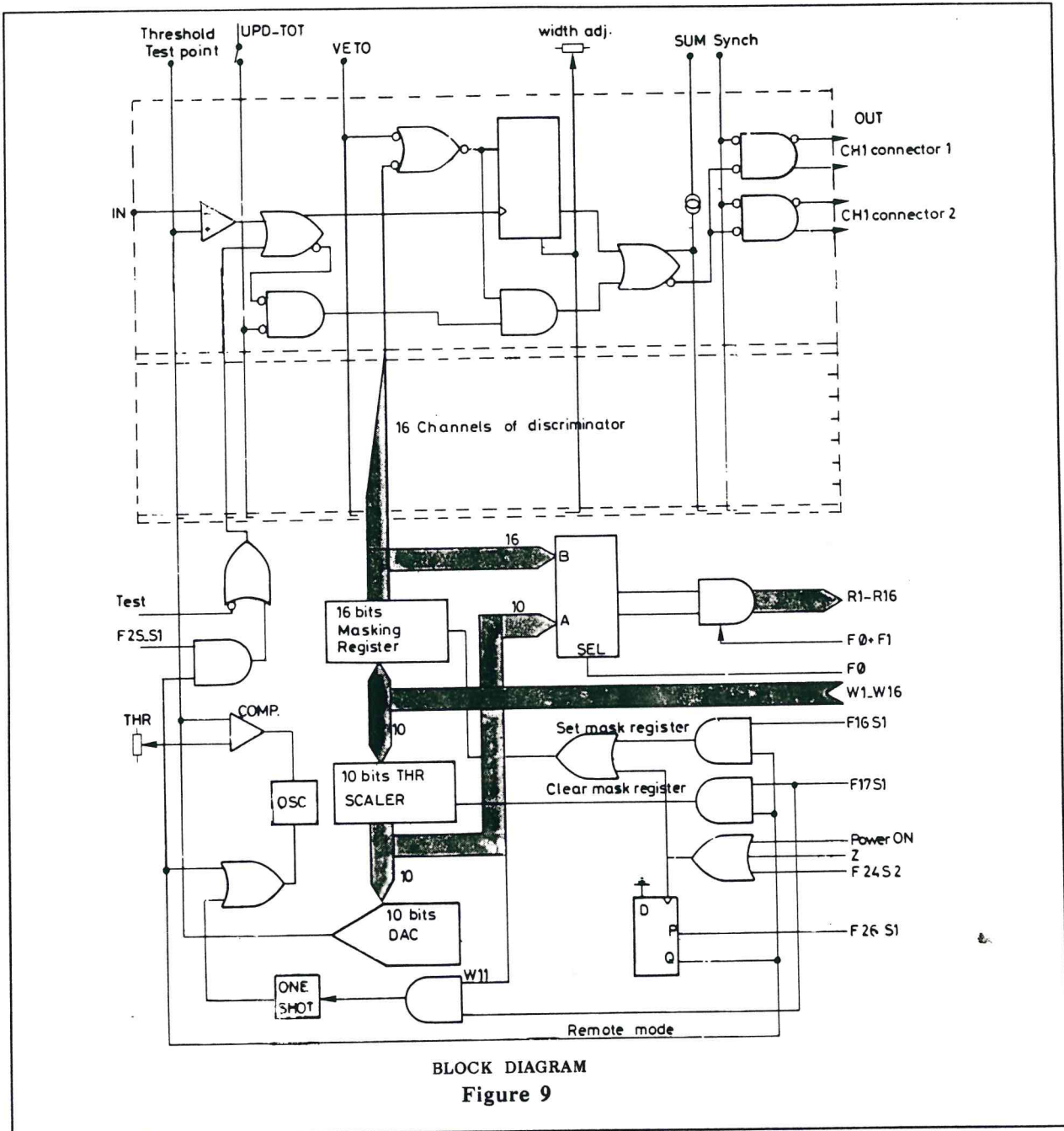

The content of the Local/Remote register, previously loaded by  $F(24) \cdot A(0)$  or  $F(26) \cdot A(0)$ , decides whether parallel or serial loading of the scaler is performed. In both cases, CAMAC readout of the scaler content is always possible via  $F(1) \cdot A(0)$ . The threshold value will be read on read lines R1 to R10.



Even when in Remote mode, it is always possible to load the DAC with the threshold value provided by the front-panel potentiometer. The user should execute an  $F(17) \cdot A(0)$  with  $W11=1$ . All the other write lines will be disregarded in this case while  $W11$  triggers a monostable (G2, LS123 in sheet 5 of schematics) enabling the oscillator for serial loading of the scaler.

**VETO and Mask**

The VETO input acts simultaneously on the 16 channels. The NIM level input signal is first translated into an ECL level signal (transistor Q1 in sheet 3 of schematics) and then OR'd with the 16 individual mask register bits (J3 and I4, both 74LS374, sheet 6 of schematics). The Veto action depends on the operation mode of the unit (Updating or Burst Guard) as described in Section 2 page 8.

**Sync-Strobe**

The Sync-Strobe input acts simultaneously on the 16 channels. The NIM level input signal is first translated into an ECL level signal Transistor Q2 in sheet 1 which, after a driver (2N5770, BFQ32), is distributed to the output gates and drivers (A1 to A8, MC10101 in sheet 1) through a low impedance line.

**Test**

The Test input acts simultaneously on all the channels that have not been masked out. The NIM level input signal is first amplified (transistors Q3 and Q4, both A401 in sheet 3 of the Schematics) and the injected by the transistors Q5 and Q6 into a low impedance line distributing the signal to all channels. The test pulse also can be generated by  $F(25) \cdot A(0) \cdot S1$ .

**Analog Sum**

Each hybrid HVL210 features a sum output generating a current of 2 mA/hit. Channels 1 to 8 and channels 9 to 16 are wired OR'd and the total sum is built up by a common base transistor (Q14, 2N5770 in sheet 3). The transistor Q7 (2N5771) has the function of generating an adjustable current to compensate for the 1 mA polarization current of Q14.

**CAMAC Decoder**

The CAMAC functions are decoded in a standard way using 74LS154, 4931 (sheet 5) and few other gates. The signal S1 is integrated by a time constant of approximately 30 nsec. The Data Selectors/Multiplexers (I5, J4, J5, all 74LS257 in sheet 6) permit reading out of the threshold register via F1 or of the mask register, through a buffer, via F(0). At power on, an RC (33 k $\Omega$ /6.8  $\mu$ F) generates a pulse setting the flip flop H1 (H1, 74LS74 in sheet 5). The flip flop forces the unit to be in Local mode.

### Power Distribution

In order to eliminate the output width variation as function of the power supply, and also because of the stable low current generator needed for the 100 nsec width output, the  $-5.0$  V is regulated and filtered on board by a LM301 (H6) and a N-channel sipmos transistor (J6, BUZ10 in sheet 7). The  $\pm 15$  V for the DAC 210 are obtained from  $\pm 24$  V using the regulator F2 (IC4501) while the  $-2$  V are built by H7 (LM337T). The power consumptions per each voltage are as follows:

-6 V;	4.1 A;	24.6 W
+6 V;	1.3 A;	7.8 W
+24 V;	30 mA;	0.72 W
-24 V;	30 mA;	0.72 W

Total power consumption: 33.84 W. Due to the high power consumption of this module it is recommended, in particular when several 4413s are used in the same crate, to carefully control the maximum power per voltage deliverable by the crate and make sure that suitable ventilation is assured.

PART NUMBER	DESCRIPTION REMARK	QTY PER
102412082	CAP CERA DISC 100V 8.2 PF	1
102412101	CAP CERA DISC 100V 100 PF	3
102412220	CAP CERA DISC 100V 22 PF	1
102412390	CAP CERA DISC 100V 39 PF	1
103327103	CAP CERA MONO 50V .01 UF	110
103427104	CAP CERA MONO 100V .1 UF	32
142824685	CAP TANT DIP CASE 6.8 UF	12
161030000	RES COMP ZERO OHMS	2
161225100	RES CARBON FILM 10 OHMS	1
161225101	RES CARBON FILM 100 OHMS	1
161225102	RES CARBON FILM 1 K	3
161225103	RES CARBON FILM 10 K	2
161225121	RES CARBON FILM 120 OHMS	2
161225151	RES CARBON FILM 150 OHMS	1
161225153	RES CARBON FILM 15 K	1
161225182	RES CARBON FILM 1.8 K	1
161225200	RES CARBON FILM 20 OHMS	1
161225203	RES CARBON FILM 20 K	2
161225221	RES CARBON FILM 220 OHMS	2
161225222	RES CARBON FILM 2.2 K	1
161225224	RES CARBON FILM 220 K	1
161225270	RES CARBON FILM 27 OHMS	16
161225390	RES CARBON FILM 39 OHMS	2
161225391	RES CARBON FILM 390 OHMS	1
161225473	RES CARBON FILM 47 K	1
161225510	RES CARBON FILM 51 OHMS	4
161225560	RES CARBON FILM 56 OHMS	2
161225561	RES CARBON FILM 560 OHMS	1
161225680	RES CARBON FILM 68 OHMS	16
161225682	RES CARBON FILM 6.8 K	1
161225910	RES CARBON FILM 91 OHMS	1
161335100	RES CARBON FILM 10 OHMS	1
161335102	RES CARBON FILM 1 K	3
161335102	RES CARBON FILM 1 K	19
161335103	RES CARBON FILM 10 K	4
161335120	RES CARBON FILM 12 OHMS	2
161335150	RES CARBON FILM 15 OHMS	1
161335161	RES CARBON FILM 160 OHMS	1
161335181	RES CARBON FILM 180 OHMS	1
161335183	RES CARBON FILM 18 K	1
161335243	RES CARBON FILM 24 K	1
161335271	RES CARBON FILM 270 OHMS	1
161335331	RES CARBON FILM 330 OHMS	1
161335333	RES CARBON FILM 33 K	2
161335390	RES CARBON FILM 39 OHMS	1
161335391	RES CARBON FILM 390 OHMS	1
161335470	RES CARBON FILM 47 OHMS	2
161335471	RES CARBON FILM 470 OHMS	1
161335472	RES CARBON FILM 4.7 K	1
161335510	RES CARBON FILM 51 OHMS	17
161335510	RES CARBON FILM 51 OHMS	1
161335560	RES CARBON FILM 56 OHMS	3

PART NUMBER	DESCRIPTION REMARK	QTY PER
161335621	RES CARBON FILM 620 OHMS	1
161335623	RES CARBON FILM 62 K	1
161335750	RES CARBON FILM 75 OHMS	1
161335821	RES CARBON FILM 820 OHMS	1
168531305	RES PREC RN55D 121 OHMS	1
168531477	RES PREC RN55D 7.50 K	1
168531553	RES PREC RN55D 46.4 K	1
168531577	RES PREC RN55D 82.5 K	1
168531585	RES PREC RN55D 100 K	1
180247503	RES VARI CERMET 50 K	16
181437101	RES VARI CERMET 100 OHMS	1
181437103	RES VARI CERMET 10 K	2
181437202	RES VARI CERMET 2 K	1
181457103	RES VARI CERMET 10 K	2
182537202	RES VARI CERMET 2 K	2
190042152	RESISTOR NETWORK 1.5 K	1
190042471	RESISTOR NETWORK 470 OHMS	6
190042471	RESISTOR NETWORK 470 OHMS	4
190042561	RESISTOR NETWORK 560 OHMS	4
190832152	RESISTOR NETWORK 1.5 K	4
190842152	RESISTOR NETWORK 1.5 K	1
190842471	RESISTOR NETWORK 470 OHMS	4
190842471	RESISTOR NETWORK 470 OHMS	2
200031028	IC 2-INPUT NAND SN74LS00N	2
200031049	IC D-TYP FLOP SN74LS74N	1
200031052	IC 8-INPUT NAND SN74LS30N	1
200031073	IC 2-IN POS OR SN74LS32N	2
200031086	IC 2-INPUT AND SN74LS08N	1
200031106	IC 2-INPUT EX-OR SN74LS86	1
200031931	IC 5-INPUT NAND SN4931N	1
200032010	IC 2-INPUT NAND 74LS38PC	5
200041042	IC UP/DN COUNT SN74LS191N	3
200041044	IC MULTIVIBR SN74LS123N	1
200041070	IC DAT SEL/MP SN74LS257AN	3
200071003	IC 8-BIT REGIST SN74LS374	2
200081004	IC DECODER/DEM DM74LS154N	1
200330002	IC 2-IN NOR GATE 74F02	1
204042002	IC NOR GATE MC10102P	1
204042016	IC 2-INPUT OR/NOR F10101P	12
204042016	IC 2-INPUT OR/NOR F10101P	8
207170540	IC BUFF/LINE DRIV 74LS540	2
207260210	IC 11-BIT D/A CONV DAC210	1
208011003	IC SINGLE OP AMP LM301AN	1
208011005	IC VOLT FOLLOWER LM310N	2
208011008	IC VOLT COMPARATOR LM311N	2
208021501	IC VOLT REG DUAL SG4501J	1
208122337	IC ADJ -VOLT REG LM337T	1
230110005	DIODE SWITCHING 1N4448	7
235050001	DIODE RECTIFIER 1N4139	2
240225712	DIODE ZENER 8.2V 1N5237	1
253010811	DIODE SCHOTTKY HP2811	1
256233209	DIODE LED RED TIL209A	2

PART NUMBER	DESCRIPTION REMARK	QTY PER
270110001	TRANSISTOR NPN PN2369A	3
270130401	TRANSISTOR NPN A401	2
270170001	TRANSISTOR NPN 2N5770	5
271170096	TRANSISTOR NPN UHF BFR96	1
275030032	TRANSISTOR PNP UHF BFQ32	1
275170002	TRANSISTOR PNP 2N5771	4
280190010	TRANSISTOR FET "N" BUZ10	1
300020001	BEAD SHIELDING "1/2" SIZE	16
300050001	CHOKE FERRITE SINGLE LEAD	2
377011200	LABEL "MOD 200"	1
377041046	LABEL "ANALOG OUT" 4413	1
402112001	CONN PC MTG NICKEL LEMO	18
402130001	CONN RT ANGL PC MTG LEMO	3
403119234	HDR DBL ROW RT ANGL 34	2
409172110	SWITCH TOGGLE SPDT	1
433220001	FUSE PICO II 125V 10 AMP	1
433220002	FUSE PICO II 125V 3 AMP	1
433230001	FUSE PICO 125V .25 AMP	2
454310002	HDR DIP SOLD TO PC BD 2	10
454420032	HDR SOLD TAIL/FEM 32	8
468911001	TEST POINT (JACK) WHT	2
471141001	BUS BAR 1-CONDUCTOR	1
500110001	TRANSIPAD "SMALL"	2
500460005	MOUNTING KIT FOR TO-220	2
500860302	INSULATOR FOR TO-220	2
521000004	SPACER HEX 2-56X.417	4
540206078	RAIL CAMAC STD TOP W/LIP	1
540206178	RAIL CAMAC STD BOT W/LIP	1
555430003	CAPTIVE SCREW ASSEMBLY	1
560256005	SCREW PHILIPS 2-56X5/16	4
560440003	SCREW PHILIPS 4-40X3/16	4
560440004	SCREW PHILIPS 4-40X1/4	2
560440005	SCREW PHILIPS 4-40X5/16	2
567440006	SCREW FLAT PHIL 4-40X3/8	4
568256002	SCREW FLAT PHIL 2-56X1/8	4
574409005	WASHER SHOULDER NYLON #4	2
577400001	WASHER SHAKEPROOF SIZE 4	2
580440001	NUT HEX STANDARD 4-40	2
593910001	CABLE CO-AXIAL RG178B/U	4
714413003	PC BD PREASS'Y 4413	1
714413013	PC BD PREASS'Y 4413-1	1
724413003	FRONT PANEL 4413	1
734413003	SIDE ECLINE LEFT 4413	1
734413005	SIDE CAMAC RIGHT 4413	1
794413003	REAR PNL PREASS'Y 4413	1
HVL210	IC DUAL DISCRIM HVL210	8

nd of report. 278 Details encountered.

connector 1

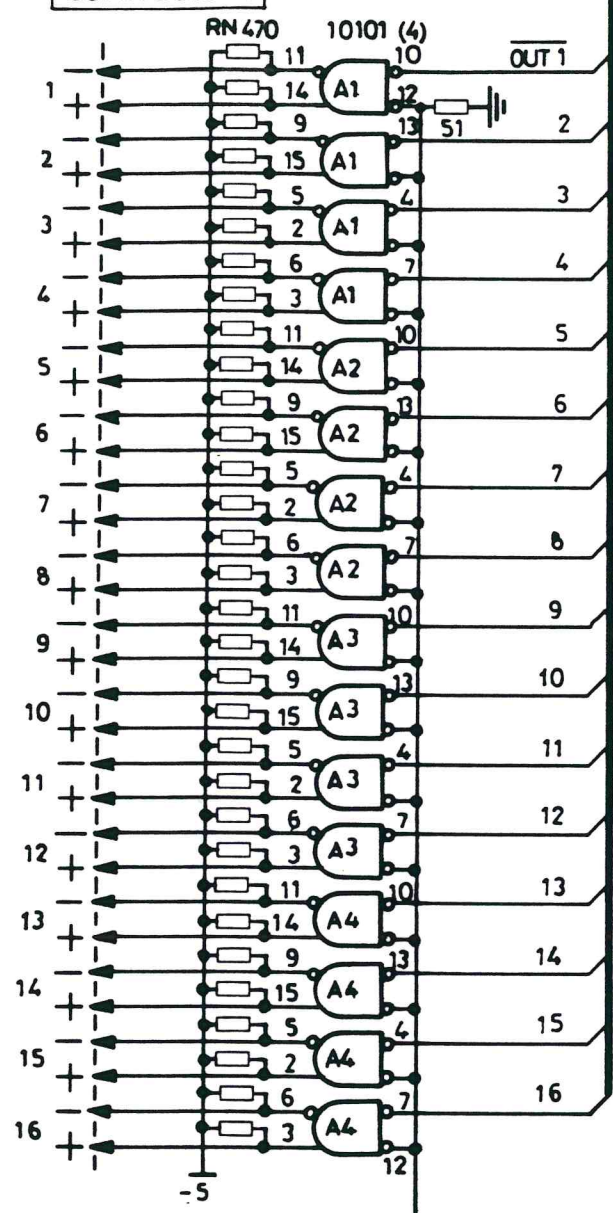

connector 2

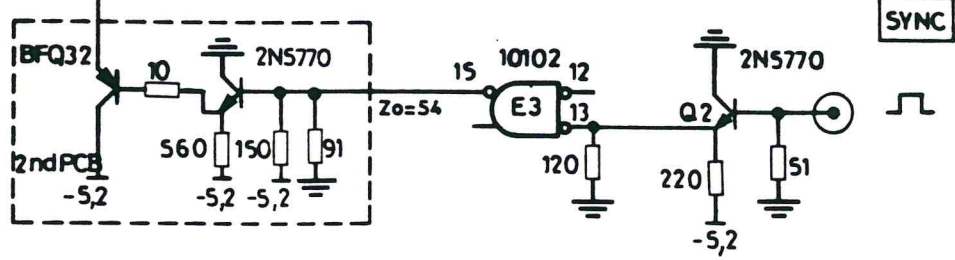
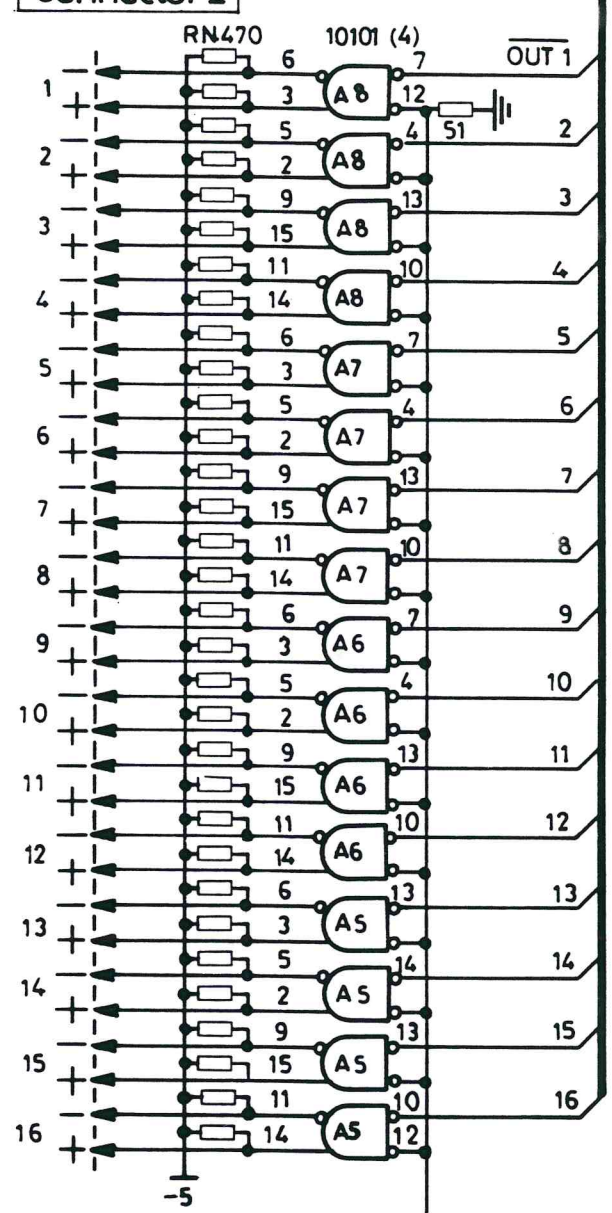

NOTICE: THIS DESIGN IS THE SOLE PROPERTY OF LeCROY CORPORATION. IT CONTAINS PROPRIETARY INFORMATION AND IS FURNISHED WITH THE UNDERSTANDING THAT IT IS NOT TO BE USED, DISCLOSED OR REPRODUCED IN ANY MANNER WITHOUT THE APPROVAL OF LeCROY CORPORATION.

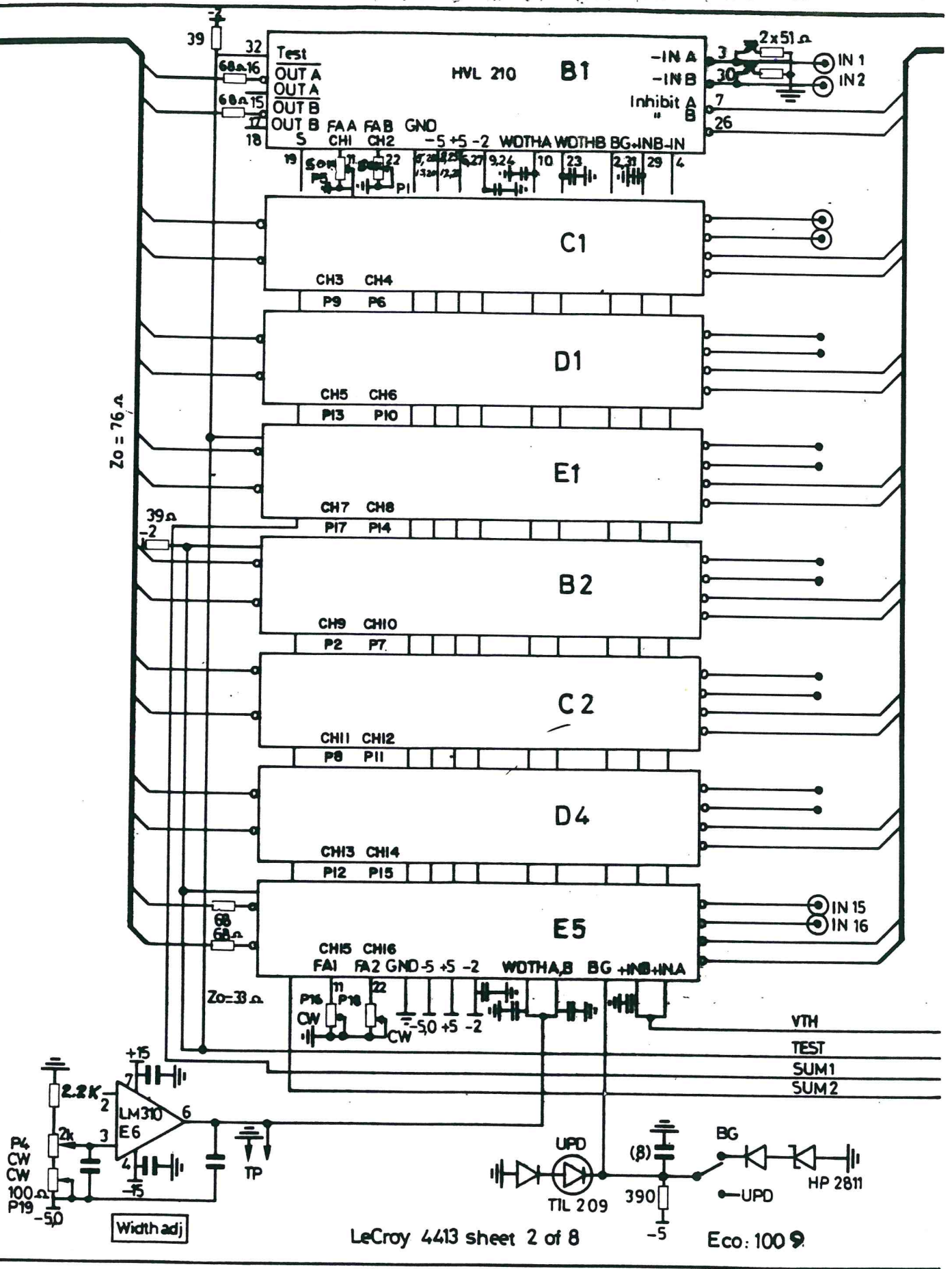

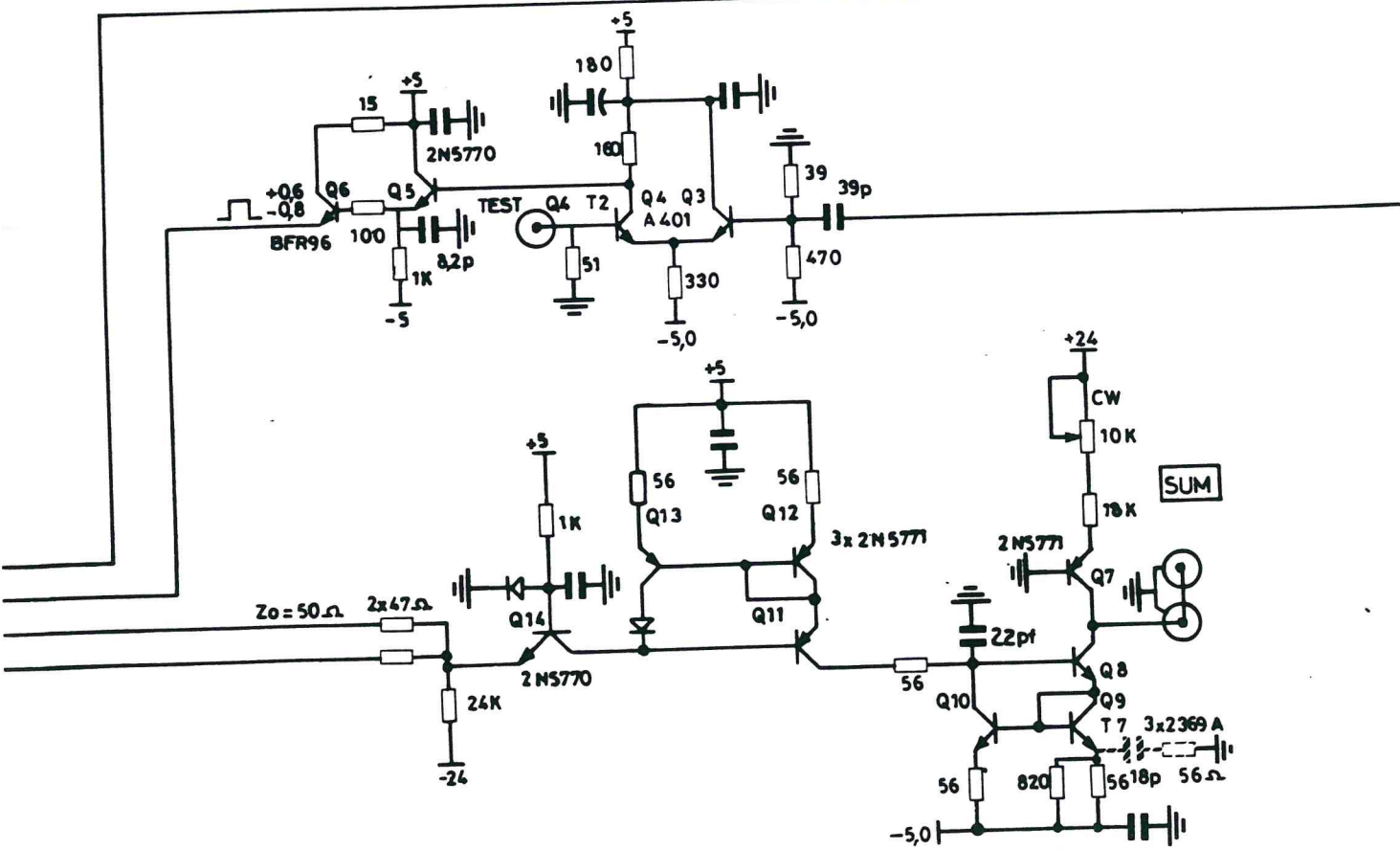
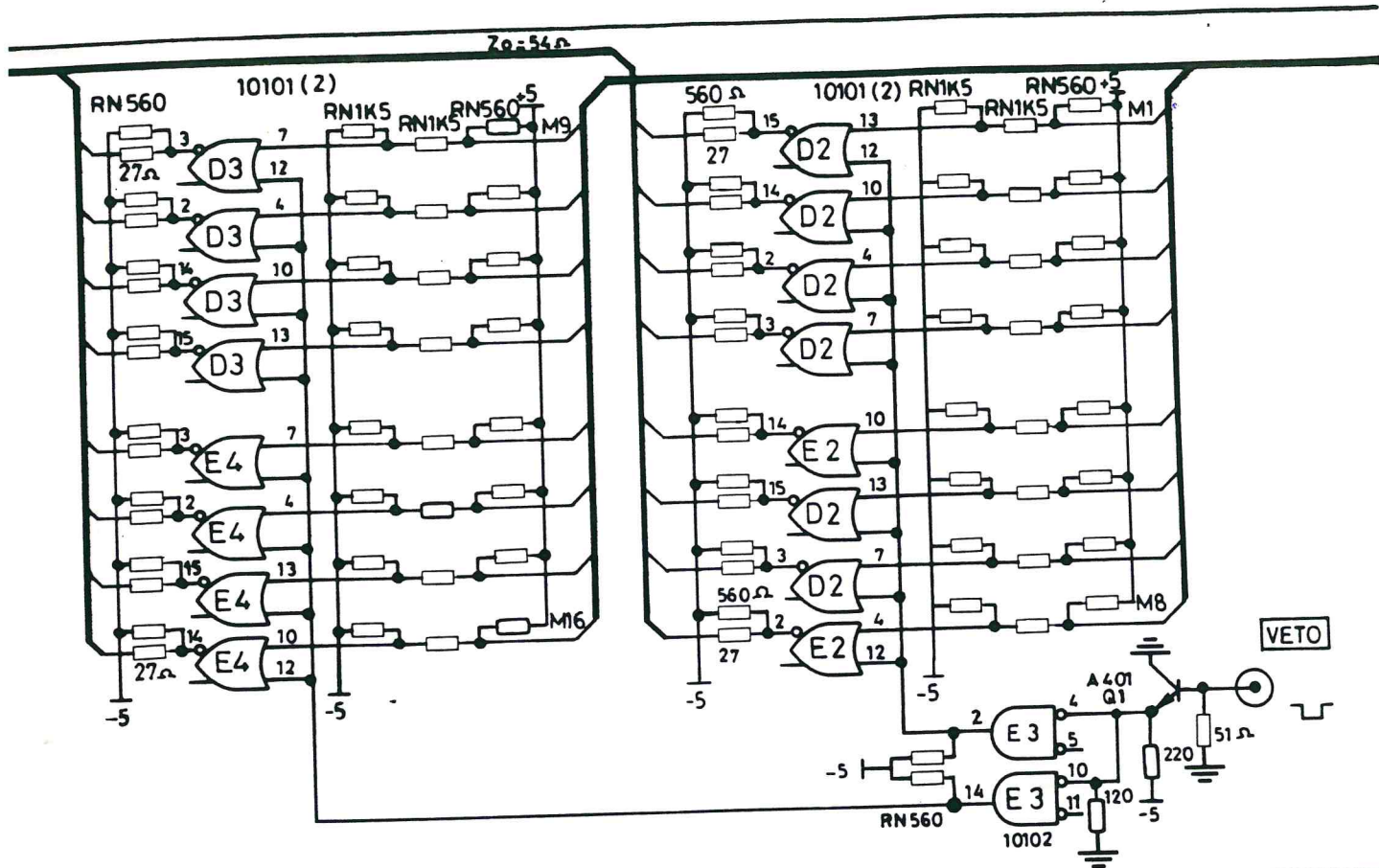



MASKS

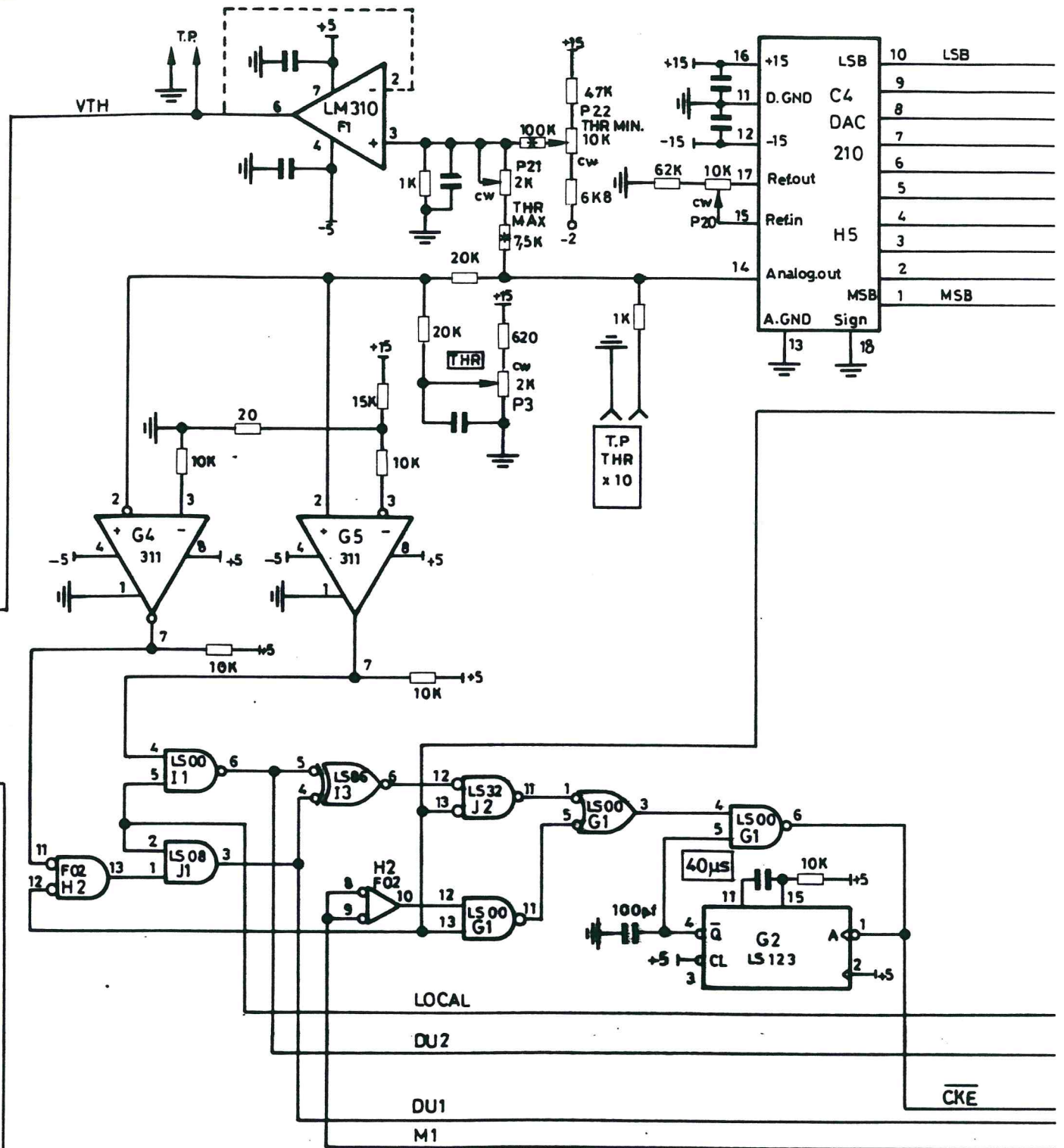

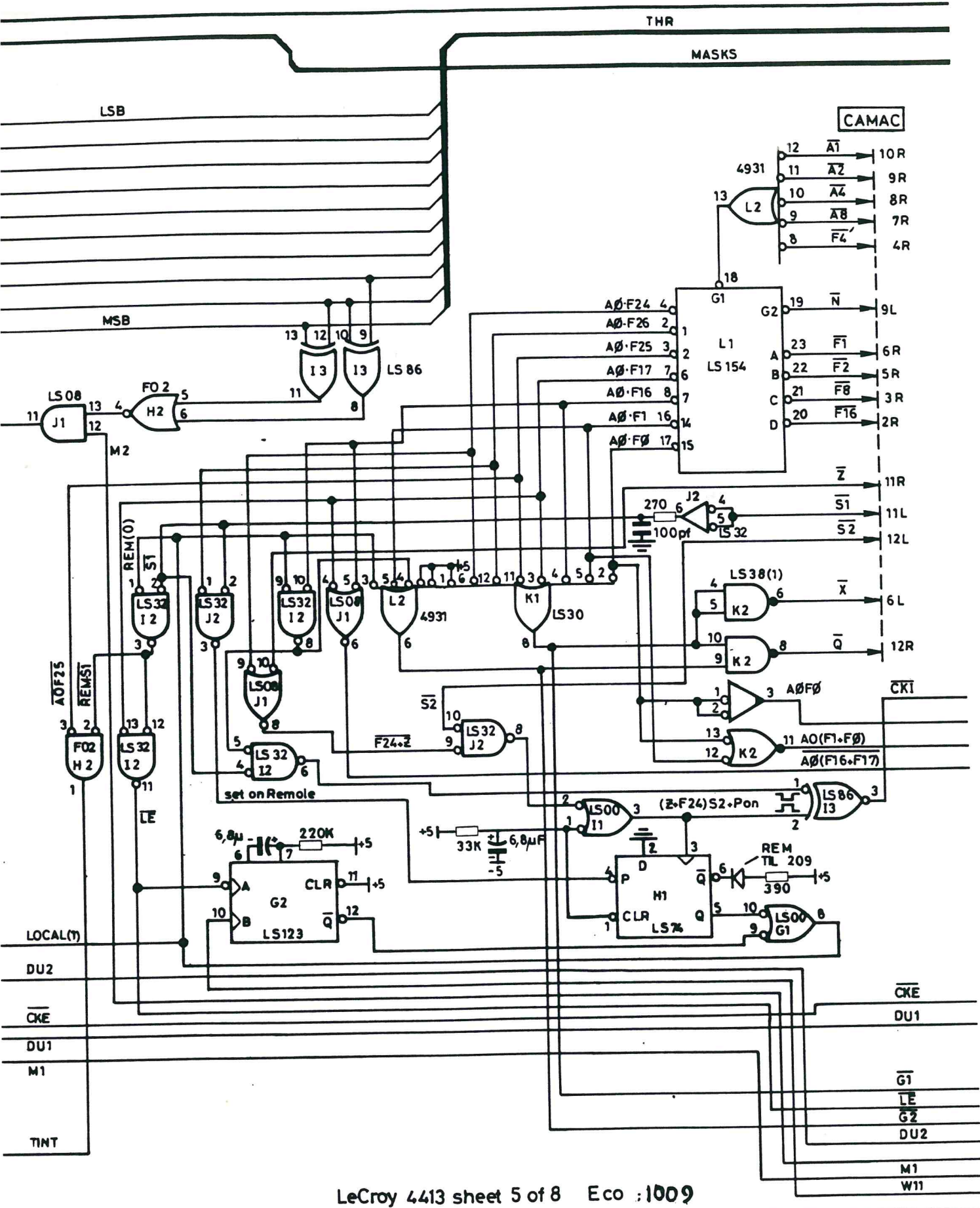

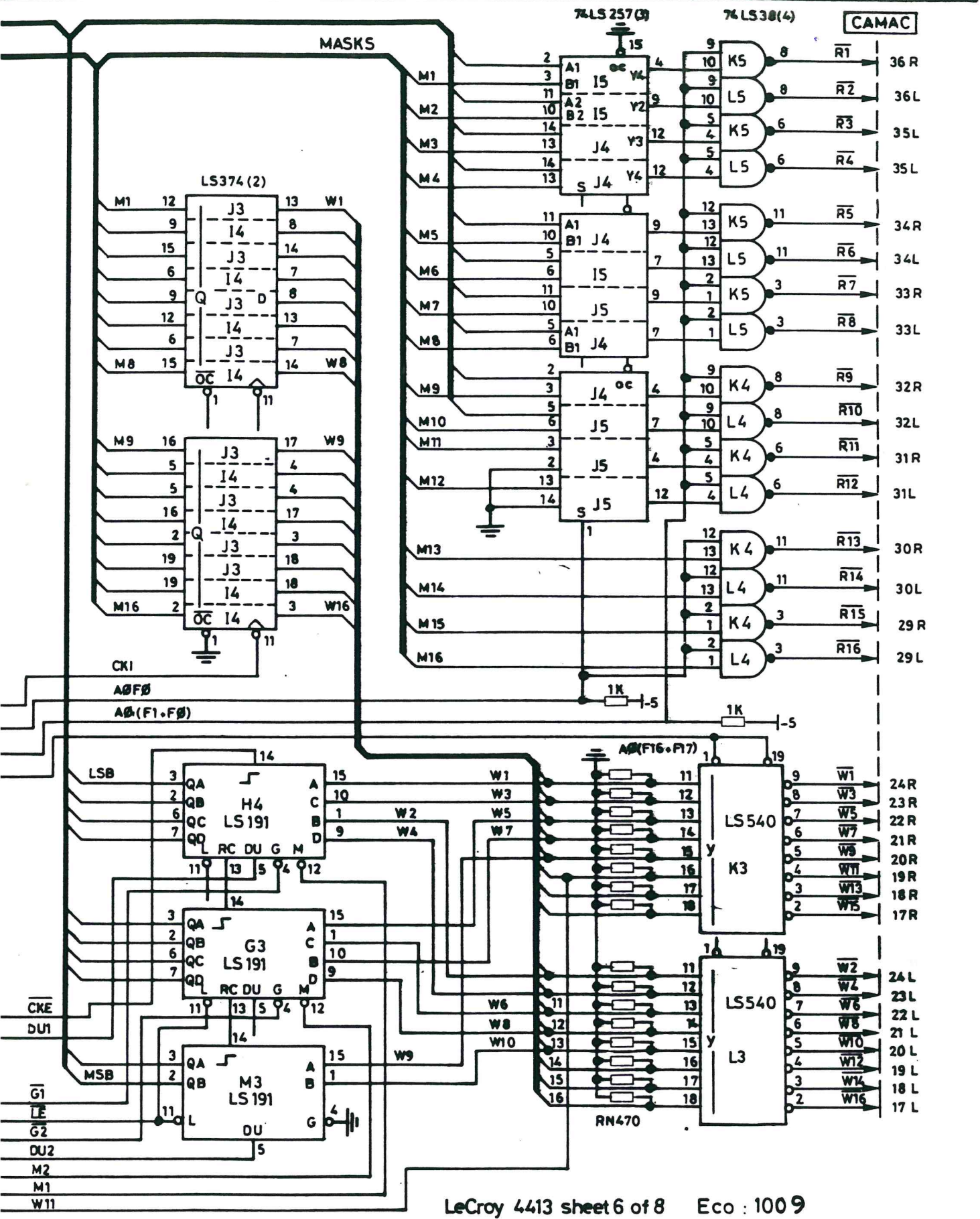

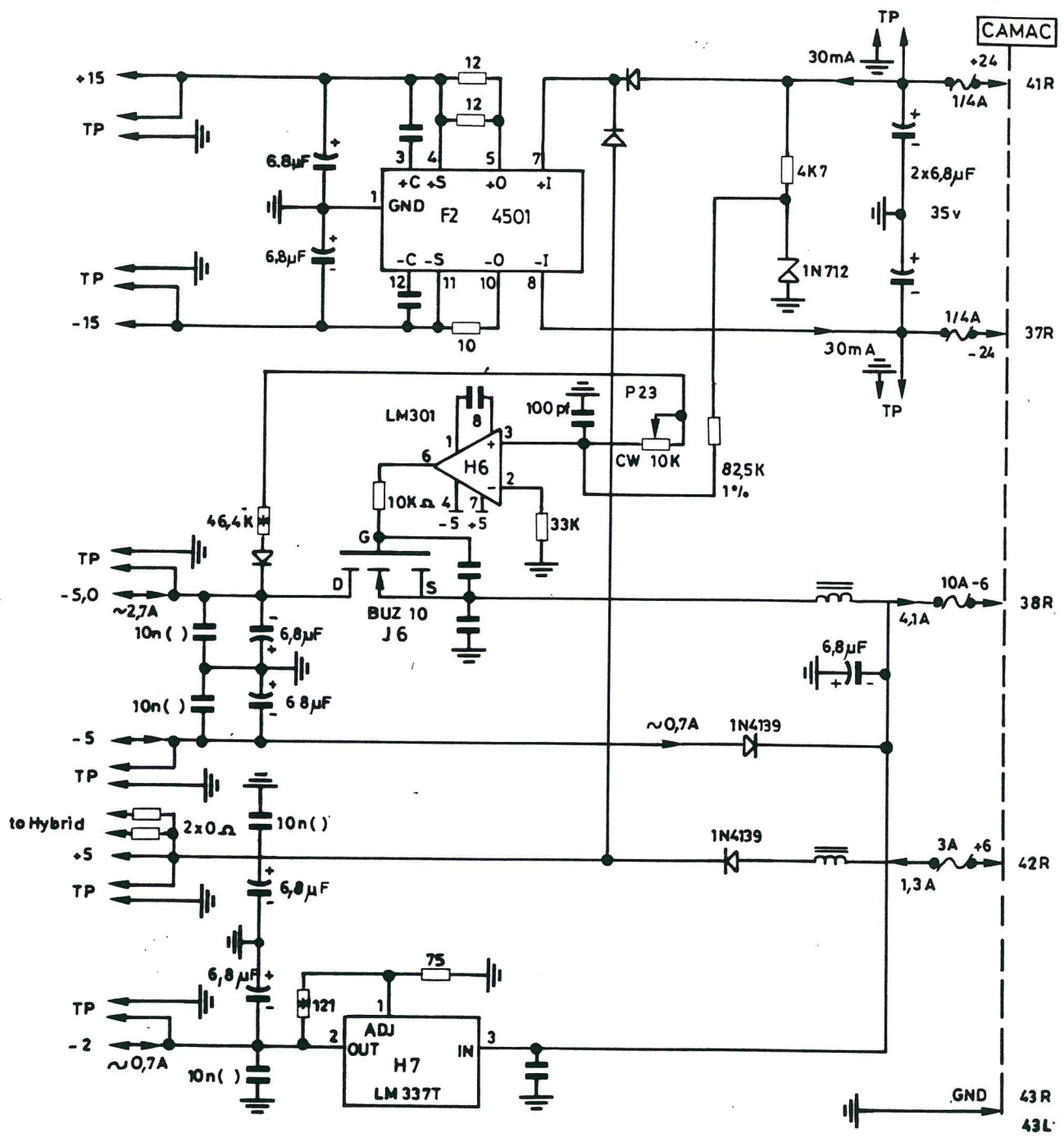

- | All unmarked | Not used  |
|--------------|-----------|
| 1N4448       | 3/4 LS 32 |
| 10nf         | 1/2 LS 74 |
|              | 1/4 LS 86 |

LeCroy part	Device	Designation	+24	+15	+5	GND	-5.0	-5	-15	-24	-2
200 031 028	74 LS 00	G1, I1			14	7					
200 031 086	74 LS 08	J1			14	7					
200 031 052	74 LS 30	K1			14	7					
200 031 073	74 LS 32	I2, J2			14	7					
200 032 010	74 LS 38	K2, K4, K5, L4, L5			14	7					
200 031 049	74 LS 74	H1			14	7					
200 031 106	74 LS 86	I3			14	7					
200 041 044	74 LS 123	G2			16	8					
200 081 004	74 LS 154	L1			24	12					
200 041 042	74 LS 191	G3, H3, H4			16	8					
200 041 070	74 LS 257	I5, J4, J5			16	8					
200 071 003	74 LS 374	I4, J3			20	10					
207 170 540	74 LS 540	K3, L3			20	10					
200 330 002	74 F 02	H2			14	7					
200 031 931	4931	L2			14	7					
208 011 003	LM 301	H6			7			4			
208 011 005	LM 310	E6, F1			7			4			
208 011 008	LM 311	G4, G5			8	1		4			
208 021 501	SG 4501	F2	7	4		1		11		8	
208 122 337	LM 337 T	H7						3(-6)			2
207 260 210	DAC 210 FX	H5		16		11.13.18			12		
204 042 016	MC 10101	A1, A2, A3, A4, A5, A6, A7, A8, D2, D3, E2, E4				1.16		8			
204 042 002	MC 10102	E3				1.16		8			
210 070 210	HVL210	B1, B2, C1, C2, D1, D4, E1, E5									
280 190 010	BUZ 10	J6									

LeCroy RESEARCH SYSTEMS			
DRAWN BY/DATE A. RUFFREUX	MODEL 4413-S1 16 CH. DISCRIMINATORS SCHEMATIC		
CHECK BY/DATE A.R.			
APPROVED BY/DATE 23-10-85	DWG NO: 4413-S1	SIZE	
SCALE	SH. 8 OF 8	ECO NO. 1009	ENG. REV. APP.